

LEDTEK[®]
Energy Saving LED

SCLED IP66 LED Waterproof Fitting



LED Batten lights are designed for the straight replacement of existing 5ft fluorescent fittings. With a smooth and even light distribution it provides up to 50% energy saving against T8 fluorescent. Applications: Warehouses, Car Parks, Supermarkets, Food Factory, Etc

Specifications:

- AC220-240V, 50/60Hz
- IP Rating: IP66
- LED Chips: SMD2835, 110Lm/W
- CCT: 4000K
- RA>80, PF>0.9
- PC Body + OPAL PC Cover
- Stainless Steel Clips
- Flicker Free Driver, ENEC Certified
- Warranty: 5 Years
- Beam Angle: 120°
- Temperature: -10° ~ +40°
- Storage Temperature: -20° ~ +80°
- Safety class: Class I
- Lifespan: 50000 hours
- CE Certification
- Normal gland on single end without through wires



CE RoHS

Available Models:

	SCLED1-4F	SCLED2-4F	SCLED1-5F	SCLED2-5F
Rated power	24W	40W	36W	60W
Lumen Output(Lm)	2640	4400	3960	7200
Input current(A)	0.15	0.25	0.17	0.3
G.W/Carton(Kg)	12	14	14.5	17
Product net weight(Kg)	1	1.1	1.2	1.4
Carton size(mm)	1225*187*252	1225*227*252	1525*187*252	1525*227*252
Qty/carton	6	6	6	6
N.W/Carton(Kg)	6	6.6	7.2	8.4

Options:

Emergency and microwave sensor versions available.

Dimensions:

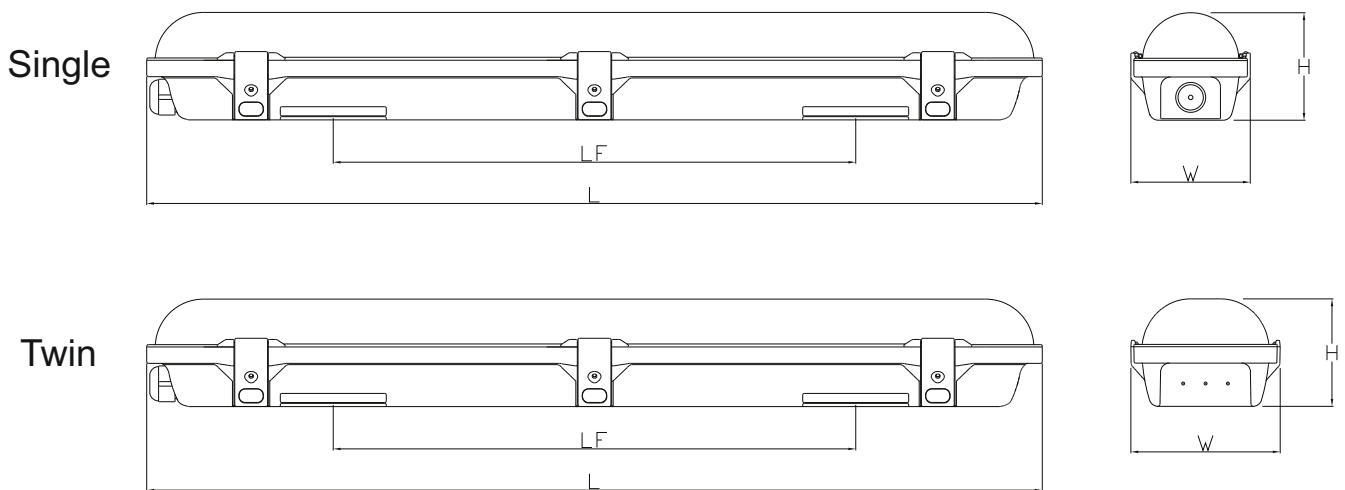

Size	L(mm)	W(mm)	H(mm)	LF(mm)
SCLED1-4F	1200	80	72	780
SCLED2-4F	1200	100	72	780
SCLED1-5F	1500	80	72	1080
SCLED2-5F	1500	100	72	1080