

LKCL18-CCT-M3-MW



Installation Sheet SLIM LED POLO

IP54 Round Bulkhead
CCT Changeable / Tri Wattage
9W/14W/18W
c/w Emergency pack
& MICROWAVE SENSOR

ERP 220-240V
COMPLIANT

These instructions should be read carefully and retained after installation for further reference and maintenance.

SAFETY

- Before installation, ensure that the mains supply to the luminaire is switched off and the circuit supply fuses are removed or circuit breaker turned off
- It is recommended that a qualified electrician is consulted or used for the installation of this luminaire and installed to the current edition of the IEE wiring regulations
- Check that the total load on the circuit, including this luminaire, does not exceed the rating of the circuit cable, fuse or circuit breaker

RATINGS

- This luminaire is of Class II construction and it does not require an earth connection
- IP54 rated
- F marked, suitable for installation on normal flammable surfaces
- Working situation: -20°C to 40°C
- 220-240V AC rated
- CE Approved

DIMENSIONS:

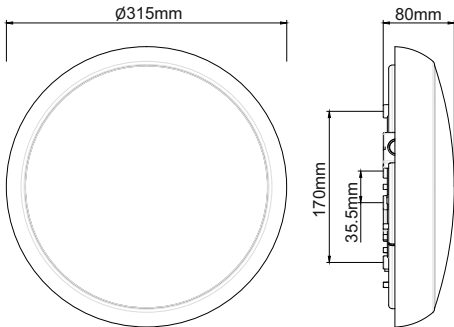

CCT & POWER ADJUSTABLE:

Switch off the mains supply before changing power or CCT

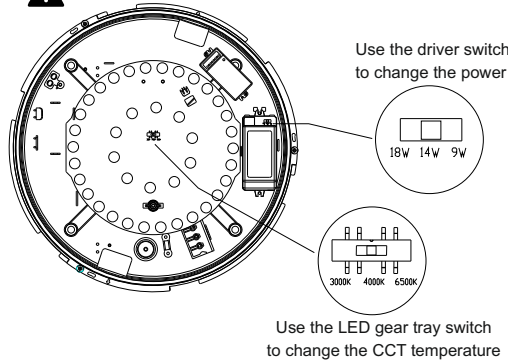

TECHNICAL SPECIFICATIONS:

- Input Voltage: 220-240V/AC
- Tri-Power Selectable: 9W / 14W / 18W
- Light Output: 9W - 900lm
14W - 1450lm
18W - 1850lm
- CCT Changeable (switch):
3000K/4000K/6500K
- CRI > 80
- IP Rating: IP54
- Protection Class: Class II
- Housing: PC Body & Diffuser

- Microwave sensor included
- Hold Time: 5s - 30min (set via 3 DIP switch)
- Sensitivity: 100% - 10% (set via 3 DIP switch)
- Daylight Sensor: 2lux - 50lux / Disable (set via 3 DIP switch)
- EM Battery Type: LiFePO4 6.4V 1000mAh
- Charge Time ≥ 24h
- Duration > 180min
- Operating Temp.: -15°C to +40°C
- Dimensions: Diameter 315mm / depth 80mm
- Warranty: 5 years (3 years for battery)

INSTALLATION INSTRUCTIONS:

Switch off the mains supply before installation.

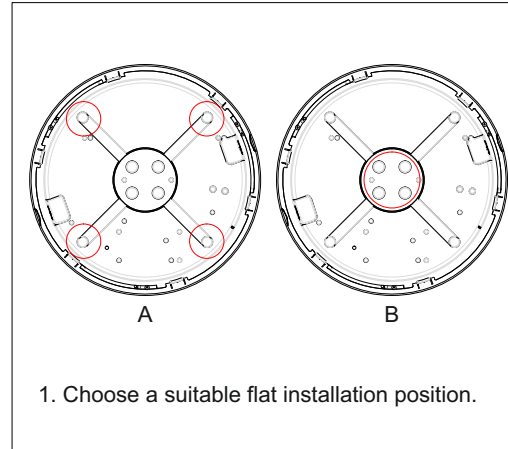

1. Choose a suitable flat installation position.

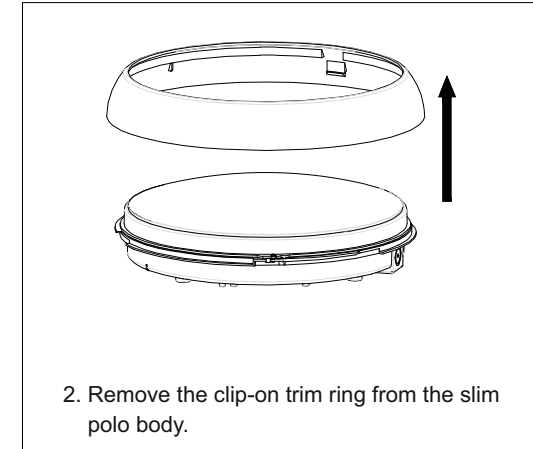

2. Remove the clip-on trim ring from the slim polo body.

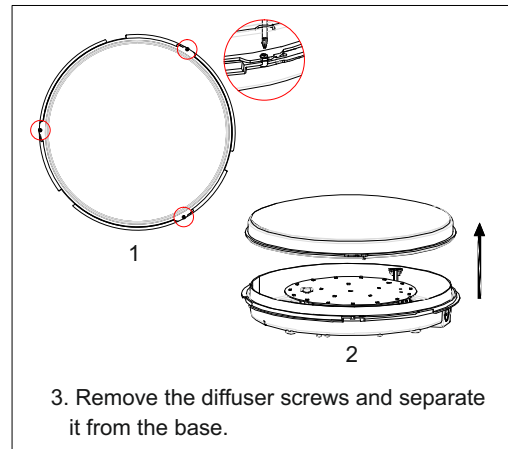

3. Remove the diffuser screws and separate it from the base.

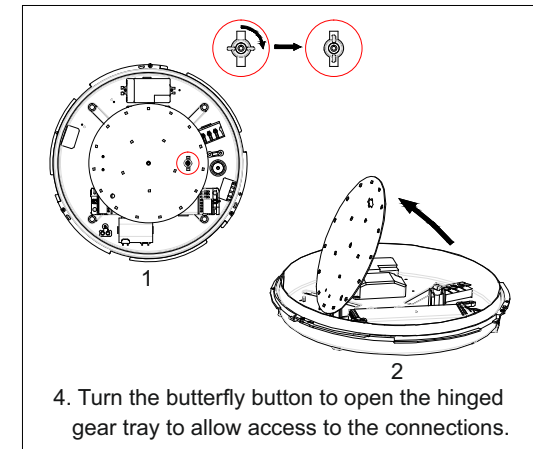

4. Turn the butterfly button to open the hinged gear tray to allow access to the connections.

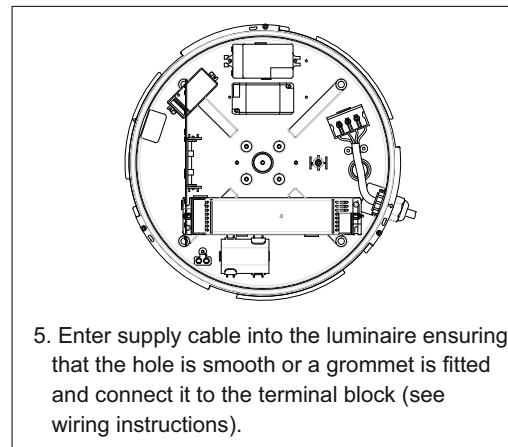

5. Enter supply cable into the luminaire ensuring that the hole is smooth or a grommet is fitted and connect it to the terminal block (see wiring instructions).

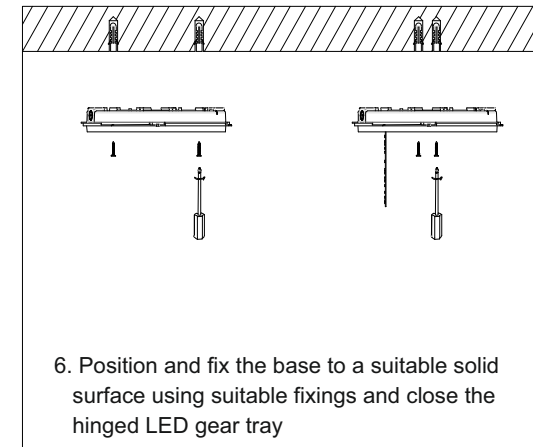

6. Position and fix the base to a suitable solid surface using suitable fixings and close the hinged LED gear tray

