

LKCL18-CCT-M3-MW MICROWAVE MOTION SENSOR INSTRUCTIONS



LED SLIM POLO BULKHEAD CCT CHANGEABLE TRI WATTAGE c/w EMERGENCY PACK & MICROWAVE SENSOR

These instructions are in addition to the standard fitting instructions that were supplied with the product you have purchased. Please read them carefully and install the fitting as per instructions, then keep the instructions for future reference and maintenance.

Installation and Safety Information

1. The light fitting should be installed as instructed in the Instructions sheet supplied.
2. The power must be turned OFF at the main power panel or fuse box prior to installation or replacing the fitting.
3. This sensor is to be connected to a 230±10% volt, 50 or 60 Hz power source. Connecting to a different power source may create a hazard and will void the warranty.
4. Do not attempt to open the sensor housing. There are no serviceable parts inside.
5. We will not accept responsibility for any claims arising from a poor installation.

Dimensions (mm):

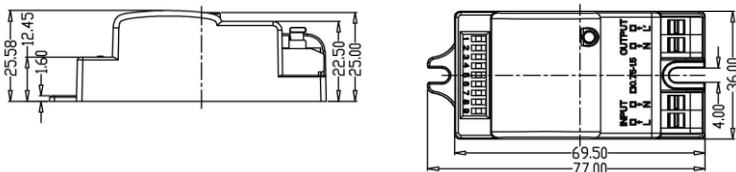

Wiring:

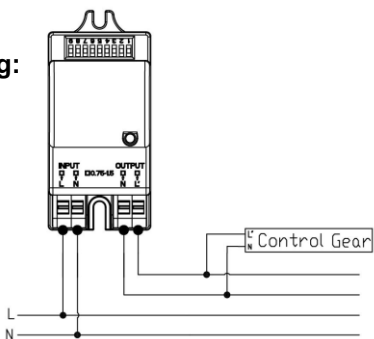

Structure:

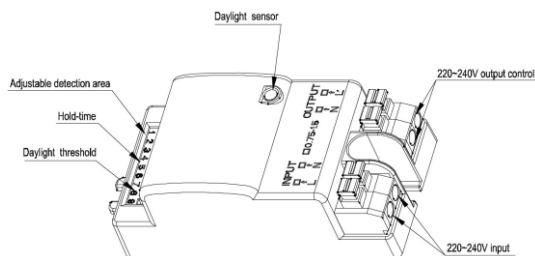

*The sensor is designed to be connected to one load only. Connecting it to more than one loads might damage the sensor.

On/OFF Function

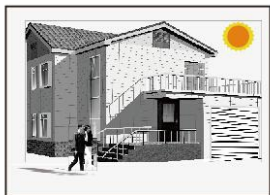

1 With sufficient ambient light, the light will not be switched on even if with motion signal.



2 With insufficient ambient light, the sensor switches on the light when motion is detected.



3 After elapse of hold time, the sensor switches off the light when no motion is detected.

Technical Specifications:

Input	Operating Voltage Range	198-264V AC, 50Hz/60Hz
	DC Input Voltage	N/A
	Rated Voltage	220-240V AC, 50Hz/60Hz
	No-load Power	N/A
	Stand-by Power	≤0.5W
	Surge Test	L--N: 1kV
Output	Working Mode	ON/OFF function
	Type of Load	Inductive or Resistive Load
	Load Capacity	400W(Inductive) ; 800W(Resistive)
	Current of Load	N/A
Max. Surge Capacity		30A (50% Ipeak, twidth =500uS, 230Vac full load, cold start)
		60A (50% Ipeak, twidth =200uS, 230Vac, full load, cold start)
Sensor Parameters	Operating Frequency	5.8 GHz ±75 MHz, ISM Band.
	Transmitting power	1mW Max.
	Hold time	5s / 30s / 90s / 3min / 20min / 30min (set via 3 DIP switch)
	Stand-by DIM Level	N/A
	Stand-by Period	N/A
	Detection Area	100% / 75% / 50% / 25% / 10% (set via 3 DIP switch)
	Daylight Sensor	2lux / 10lux / 25lux / 50lux / Disable (set via 3 DIP switch) (Ambient diffusion status)
	Daylight on/off	N/A
	Detecting Radius	4-6m (mounting height 3m)
	Mounting Height	6m Max
Detecting Angle	150°	
Operating Environment	Operating Temperature	-20°C...+60°C
	Storage Temperature	-40°C...+80°C Humidity: 10%-95% (Non-condensing)
Certificate Standards	Safety standards	EN61058-1, EN61058-1-2
	EMC standards	EN300440, EN301489-1, EN55015, EN61547, EN61000-3-2, EN61000-3-3, EN62479
	Environmental Requirement	Compliant to RoHS
	Certificate	CE, TUV, RED
Others	Wiring	Press-in Type Terminals, wire diameter:0.75-1.5mm ²
	IP Rating	IP20
	Protection Class	Class II
	Dimension	77*36*25.6mm
	Net Weight	41.0g
	Lifetime	5 years warranty @Ta 230V full load

Note

1. "N/A" means not available.
2. Detection area is effected on volume of motion object and motion speed. The detection area is tested by a 165cm height person and walking speed is 0.5m/s.

Radiation Pattern:

Ceiling mounting:

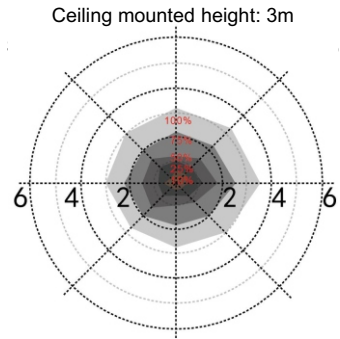

Normal moving (Speed:1m/s)

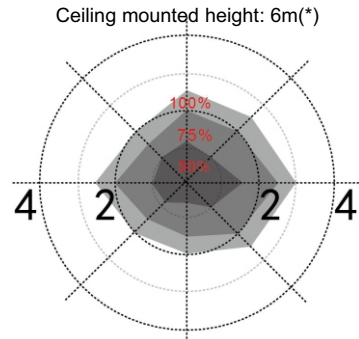

Normal moving (Speed:1m/s)

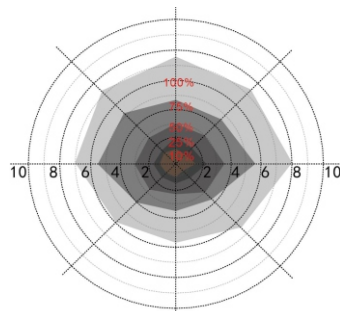

Slow moving (Speed 0.3m/s)

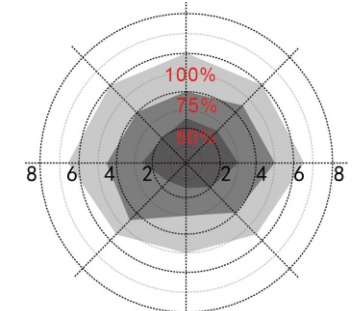

Slow moving (Speed: 0.3m/s)

* When installed at 6m mounting height the sensor detects movement only when set on 50%, 75% and 100% sensitivity. It is not able to detect movement if the sensitivity is set to 10% or 25%.

Wall mounting:

Wall mounted height: 2m
Sensitivity: 100%/75%/50%/25%/10%

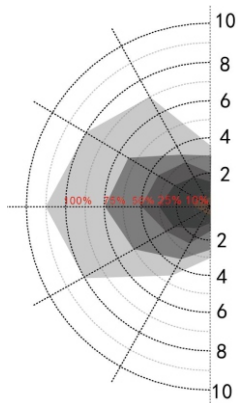

Normal moving (Speed: 1m/s)

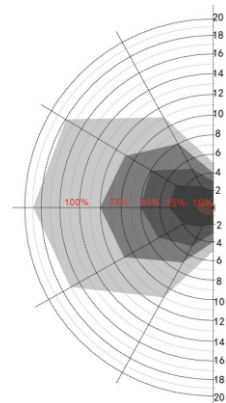

Slow moving (Speed 0.3m/s)

DIP Switch Settings:

Be sure to power off before adjusting DIP switch setting.

Detection Area (Sensitivity):

	1	2	3	
I	ON	ON	ON	100%
II	-	ON	ON	75%
III	ON	-	ON	50%
IV	-	-	ON	25%
V	-	-	-	10%

Hold Time:

	4	5	6	
I	ON	ON	ON	5S
II	-	ON	ON	30S
III	ON	-	ON	90S
IV	-	-	ON	3min
V	ON	ON	-	20min
VI	-	-	-	30min

Daylight Sensor:

	7	8	9	
I	ON	ON	ON	2Lux
II	ON	ON	-	10Lux
III	-	ON	-	25Lux
IV	ON	-	-	50Lux
V	-	-	-	Disable*

*Disable means that the daylight sensor does not work. The sensor will turn on the light once motion is detected regardless of the ambient light level.

Initialization:

After power on, the sensor automatically turns on the light at full brightness and enters the initialization mode for 10 seconds. During the initialization the sensor is not able to detect any movement.

Factory Settings:

Detection Area: 100%, Hold Time: 5sec, Daylight Sensor: Disabled

High Environmental Adaptability

The microwave motion sensor has high reliability, its detection range is less affected by temperature, wind, airflow, sound, light, fog, smoke, dust, etc.

High Sensitivity for Occupancy Detecting

This product can detect the slightest movement, such as lifting an arm, turning round, stooping etc. In addition, unlike infrared sensor, the microwave sensor has no directional characteristics. Movement in any direction can be detected.