



LEDTEK® Installation Sheet

Ultra Slim COB LED Floodlights with PIR Sensor 10W/30W/50W



Please read these instructions before commencing installation and retain them for future reference.

Important information

It is recommended that floodlights are installed by a qualified electrician ensuring the installation complies to current IEE wiring regulations & local building control.

- These products are designed for connection to a 220-240V mains supply.
- Any broken or damaged parts should be replaced as soon as possible.
- We will not accept responsibility for any claims arising from a poor installation.

Specifications:

- Voltage Range: 220-240V
- Nom. Watts: 10W / 30W / 50W
- Beam Angle: 120°
- IP Rating: IP65 Body / IP44 PIR sensor
- Warranty: 3 Years
- Die Cast Aluminium Casing
- Shatter Resistant Tempered Glass
- Not Dimmable
- Protection against electric shock: Class I Requires earth connection
- With Connection Box

- Includes additional Wall Mounting bracket
- Optional Garden Spike (not included)
- Operational Temp.: -20°C ~ +40°C

Sensor Specifications:

- Up to 10m Detection Range
- Time adjustment: 10sec. - 10min.
- Lux adjustment: 3 ~ 2000lux
- Detection Angle: 140°
- Mounting Height Recommended: 1.8 to 2.5m (2.9m max)
- Pulse Override Facility

Dimensions:

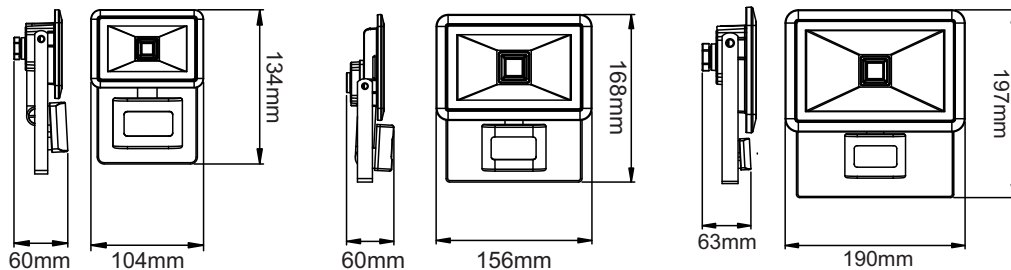

USF10PIR

USF30PIR

USF50PIR

INSTALLATION INSTRUCTIONS:



Always switch off mains supply before servicing.
The distance between two floodlights should be no less than 50cm.

CHOOSING A MOUNTING LOCATION

- For the best results, fix your sensor on a solid surface, 1.8~2.5M above the ground
- For outdoor installation, a location under eaves is preferable
- Avoid aiming the motion sensor at pools, heating vents, air conditioners or objects that may change temperature rapidly
- Do not allow sunlight to fall directly on the front of unit
- Try to avoid pointing the unit at trees or shrubs or where the motion of pets may be detected
- When choosing the mounting position consider that the sensor is more sensitive to motion across the detection field (A) and less sensitive to motion directly towards the sensor (B) (Figure 1)
- Select a location for the unit based on the coverage angles shown in Figure 2

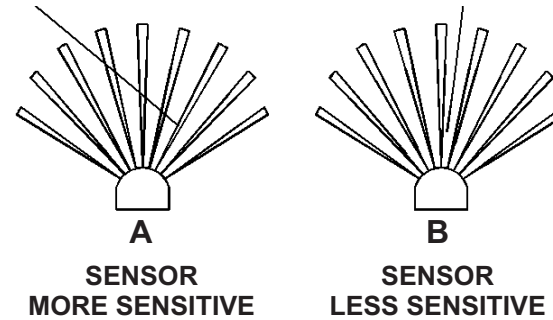

SENSITIVITY TO MOTION
Figure 1

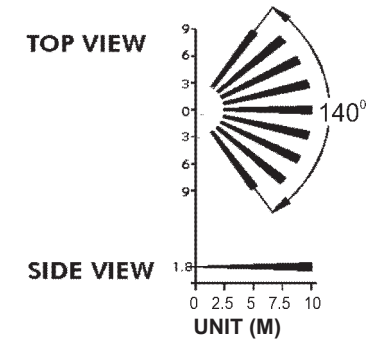

COVERAGE ANGLES
Figure 2

COVERAGE RANGE

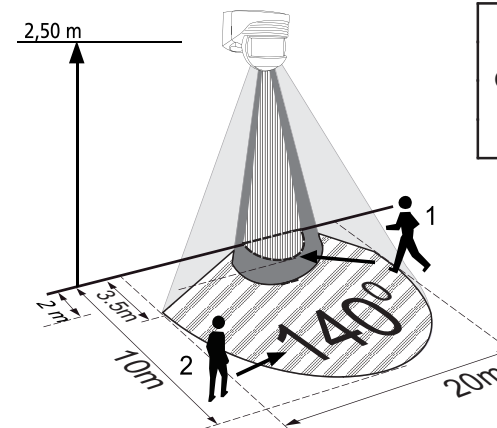

- 1 ■ Walking Towards
- 2 ▨ Walking across

WIRING INFORMATION

Connection Box	220-240V Input
	Brown = Live
	Blue = Neutral
	Green/Yellow = Earth

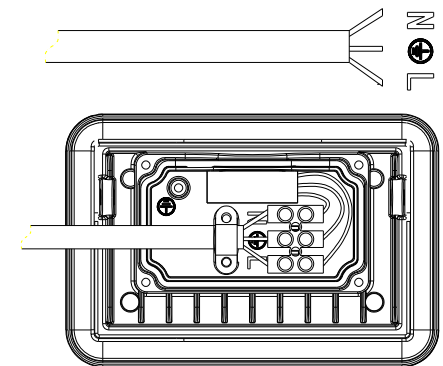

PULSE OVERRIDE FACILITY

The Ultra Slim Floodlights with PIR have a **Pulse Override** facility to enable lighting to be switched on for long periods using an existing switch.

For pulse override switch the **power OFF then ON twice within 1 second** to enable constant light. In constant light mode turn OFF then ON after 10 seconds to enable sensor mode.

Installing the Cable:

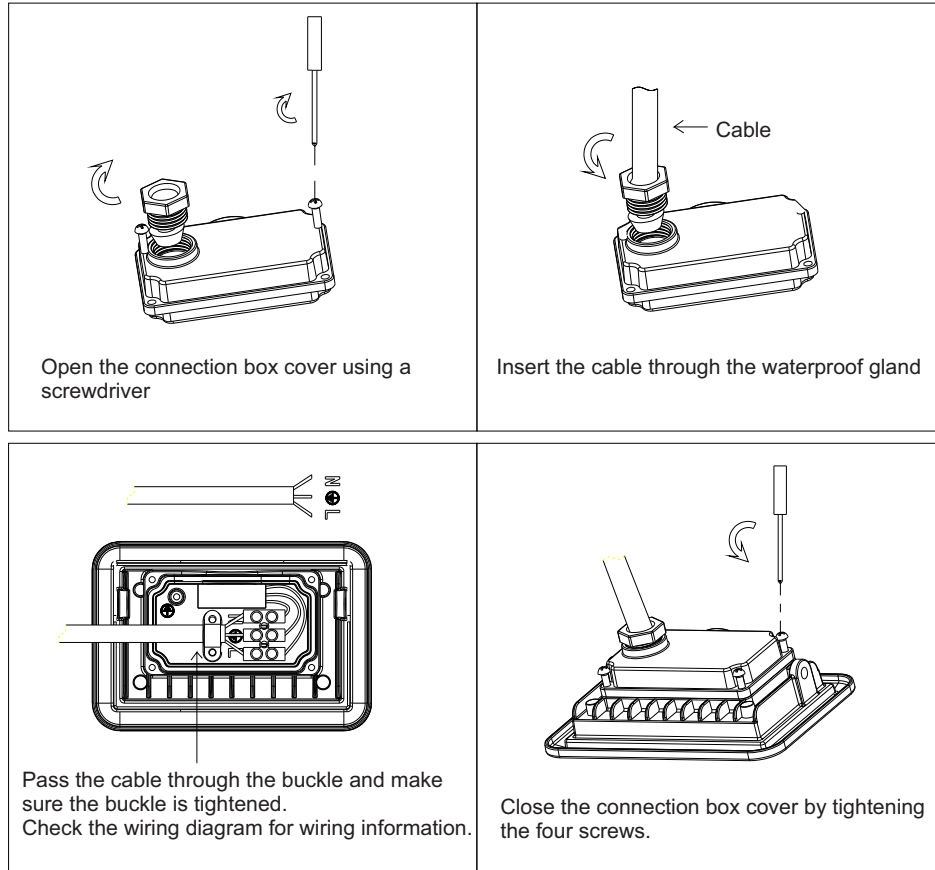

Installing the Bracket:

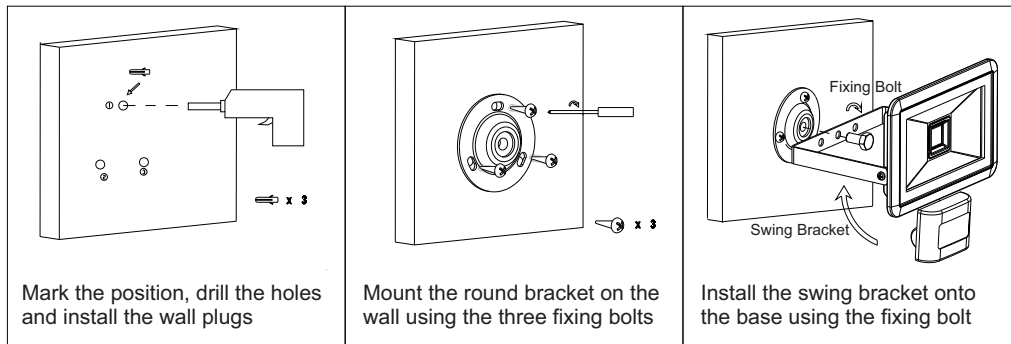

WARNING: Ensure all items and screws are secure and fitted correctly.

- Turn On Power and test the luminaire
- This floodlight is not dimmable
- Floodlights should not be connected in series

SETTING THE PIR SENSOR

1. TEST MODE

Turn the Time, Sens and Lux control anti-clockwise to the edge – the TEST position.

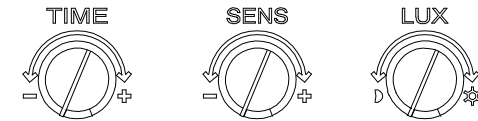

Turn the wall switch on. The floodlight will turn on for about 10 seconds to warm up. It will then turn off. Walk through the detection area. The floodlight turns on when you move and turns off when you stop. Wait for the floodlight to turn off before moving again to test the sensor. Adjust the motion sensor to cover the desired detection area.

2. TIME ADJUSTMENT

The TIME adjustment controls how long the floodlight will stay on after motion has been detected. Turn the time control knob clockwise to increase how long the floodlight stays on (up to approx. 10 minutes) or anti-clockwise to decrease the time the floodlight stays on (down to about 10 seconds).

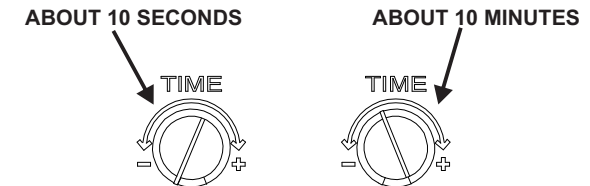

3. LUX ADJUSTMENT

The LUX adjustment determines at what light level the lighting system will start operating when you set the sensor to automatic operation.

Provisionally turn the LUX control knob to the edge anti-clockwise to the moon (dusk) position. In this setting the motion sensor remains inactive during daylight. At dusk when the light level is at the LUX required adjust the knob clockwise to when the light comes on.



4. SENSOR ADJUSTMENT

The sensitivity adjustment may be adjusted to compensate for seasonal variations in temperature and to reduce unwanted triggering. The optimum sensitivity can be achieved by setting the SENS control knob initially to its mid-point and then adjusting the control knob clockwise to increase the detection distance (up to 10 metres) or anti-clockwise to decrease the detection distance (down to 2 metres).

