

LEDTEK User Instructions

EM-BL3ST **BLADE** LED Emergency Exit Box c/w Self-test Function



Please read these instructions and retain them for future reference.

Important information:

It is recommended that this fitting is installed by a qualified electrician ensuring the installation complies with current IEE wiring regulations & local building control.

- This product is designed for connection to a 220-240V mains supply.
- This product is for indoor use only.
- We cannot accept responsibility for any claims arising from a poor installation.
- Always switch off mains supply before installation.
- The light fitting is Class II and does not require an earth connection.

Technical Specifications:

- | | |
|---|---|
| • Input Voltage: 220-240V/AC | • Charge Time ≥ 24h |
| • Power: 2.5W | • Duration > 180min |
| • Light Output: 45Lm(charging)
25Lm(discharging) | • IP Rating: IP20 |
| • Viewing Distance: 30m max. | • Protection Class: Class II |
| • Test method: Self-test | • Housing: PC Body & Diffuser |
| • CCT: 6500K | • Wall Mounting |
| • CRI > 80 | • Operating Temp.: -15°C to +40°C |
| • Battery: LiFePO4 3.2V 1000mAh | • Easy Rotating PVC Legends included |
| | • Warranty: 3 years (excluding battery) |

Dimensions:

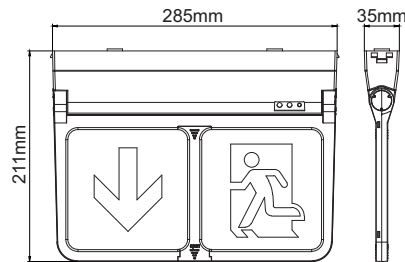

Wiring Diagram:

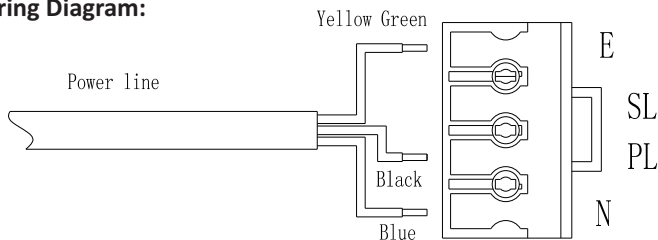

Installation Instructions:

Switch off the mains supply before installation.

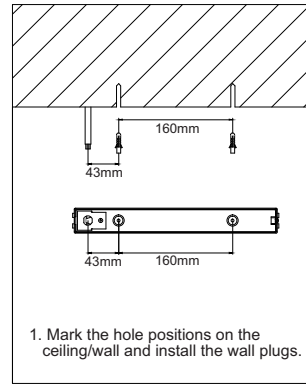

1. Mark the hole positions on the ceiling/wall and install the wall plugs.

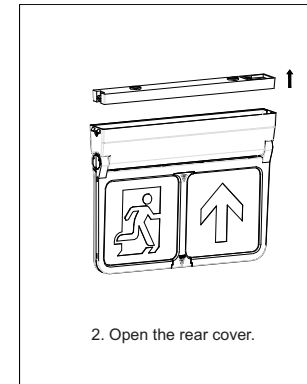

2. Open the rear cover.

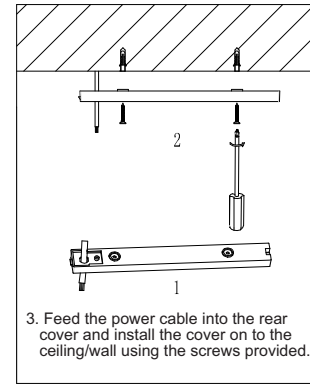

3. Feed the power cable into the rear cover and install the cover on to the ceiling/wall using the screws provided.

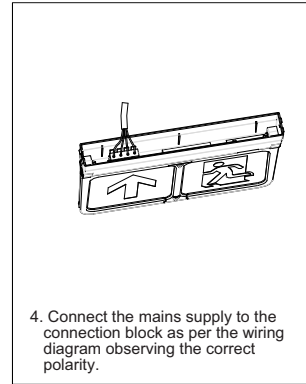

4. Connect the mains supply to the connection block as per the wiring diagram observing the correct polarity.

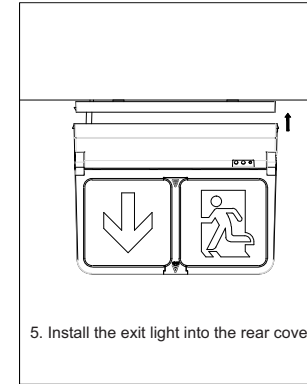

5. Install the exit light into the rear cover.

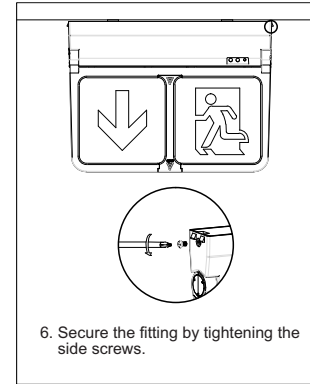

6. Secure the fitting by tightening the side screws.

Replacing the legend:

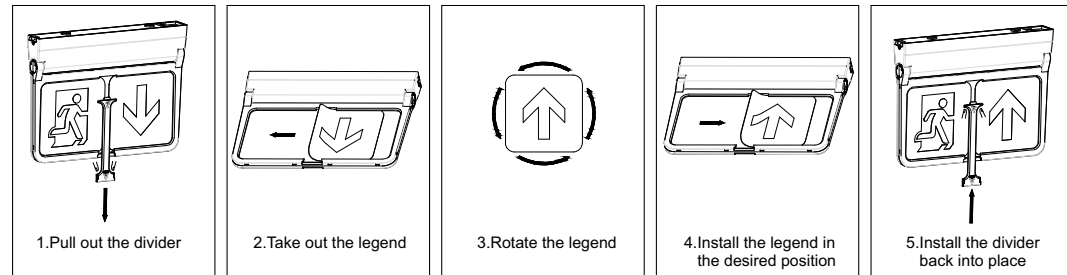

Emergency Testing and Battery Maintenance:

- Initial battery charge must be for a minimum of 24 hours before testing.
- To achieve best performance the EM-BL3ST should be tested fully by switching into emergency mode regularly in accordance with local testing regulations. Any warranty claim must be accompanied by documentation which records the dates of this maintenance procedure and signed by maintenance personnel.
- When first connecting to AC power check if the Green LED light is lit confirming that the battery is charging.
- Turn the power off to simulate mains supply failure. The Green LED should go off & the exit box will be in emergency mode.
- The battery must be replaced when the unit no longer meets the rated emergency duration or if there is a battery fault.

