

Emergency Lighting Power Pack with Self Test for Mains Voltage LED Lamps



The FEM40 emergency pack is suitable for 5-20W LED lamps with internal Integrated Circuit (IC) driver (This device CANNOT be used for LED lights with Resistive Circuit (RC) driver).

The FEM40 emergency pack includes housing, PCB, battery and self-check test button with 3 colour LED indicator. The battery is a Li-ion battery with a long lifespan; the PCB uses IC control design in charging/discharging and power supply. The PCB circuit has built in protection for over-charging/discharging, output short-circuit, open circuit or input/output reverse connection.

Operating principle:

The FEM26 emergency pack charges when AC power is present. When fully charged, the circuit will protect the battery from over-charging and the emergency pack will enter stand-by mode. As soon as the AC power fails the battery will supply power to the LED lights.

It can be used in public places to ensure LED lights work normally when mains power fails suddenly because of fire, earthquake, etc.

Features:

- 5-20W LED emergency driver.
- Applicable to **LED lamps with internal Integrated Circuit (IC) driver.**
(This device CANNOT be used for LED lights with Resistive Circuit (RC) driver).
- IP30 protection level.
- Safe Voltage Output
- Overload protection: timely protection when power exceeds 50% of rated power.
- Short circuit protection and no loading protection
- High efficiency and low temperature extended lifespan (> 50000 Hours).
- External test button and three-color LED indicator
- Self-check function with annual and monthly inspection.
- Compact size, convenient for installation and maintenance.
- Fire-resistant plastic housing made of a fire-resistant PC.

Battery features:

- High capacity Lithium-Ion battery with overcharge and over discharge protection.
- High temperature resistant battery
- 11.1V Lithium-ion 6 cell battery pack 4000mAh
- Simple plug-in connection

Self-check function:

- **Monthly inspection:** The system simulates a power outage every 30 days for 35 seconds. It will quit and return to the mains power state automatically if there is no fault.
- **Annual inspection:** The system simulates a power outage every 365 days and for 3 hours or until the battery power is dissipated. It will quit and return to the mains power state automatically if there is no fault.

Dimensions:

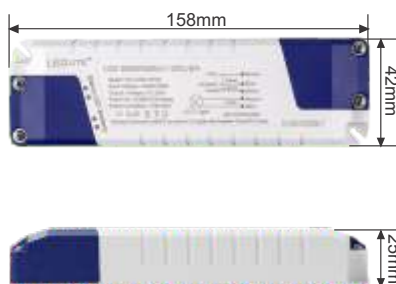

Fig. 1 Inverter Dimensions

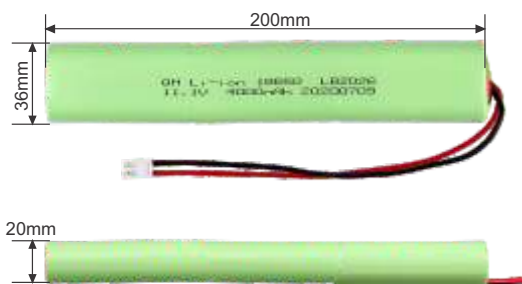

Fig. 2 Battery Dimensions

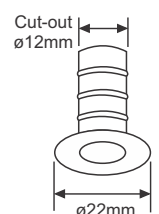

Fig. 3 Status LED Self-test Button Dimensions



LEDTEK® FEM40

Emergency Lighting Power Pack with Self Test for Mains Voltage LED Lamps

Wiring Diagram:

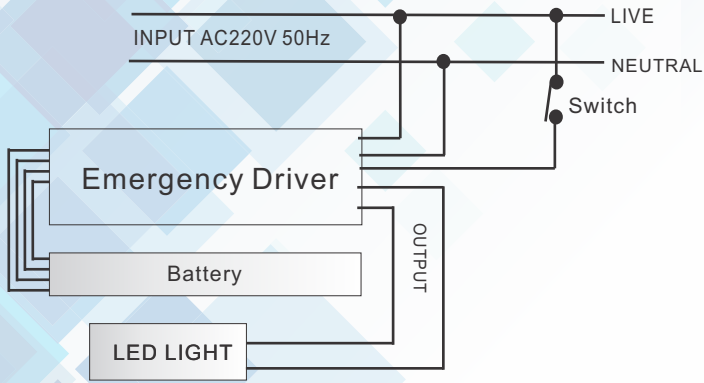

Wiring for LED Lights with Internal Driver

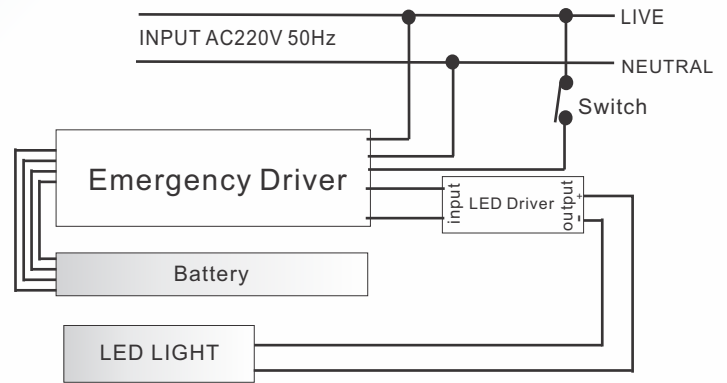

Wiring for LED Lights with External Driver

Technical Specifications:

Working Voltage	AC176-265V	Battery Type	18650 Li-Ion 11.1V 4000mAh	Dimensions	L158*W42*H25mm
Emergency Output Voltage/Current	DC 230V 0.03A-0.15A	Battery Cycle Use Times	≥500 times	Battery Dimensions	L200*W36*H20mm
Emergency Switching Time	≤5sec.	Emergency Time	≥180 minutes	Working Temperature	-5°C - +45°C
Suitable for Lamps Power (W)	5-20W	IP Rating	IP30	Storage Temperature	-5°C - +45°C
Lamp Type	LED Lamps	Luminous Flux	up to 1000 lumens	Warranty	3 years
Charging Time	24h	Weight	0.39kg	Body Material	Plastic

